

Needle roller bearings, with machined rings, with flanges, without an inner ring

Principal dimensions			Basic load ratings		Speed ratings	Limiting speed	Designation
$F_w$	D	C	dynamic C	static C0	Reference speed		
mm			kN		r/min		-
<b>90</b>	110	54	134	315	4500	5000	<b>RNA 6916</b>

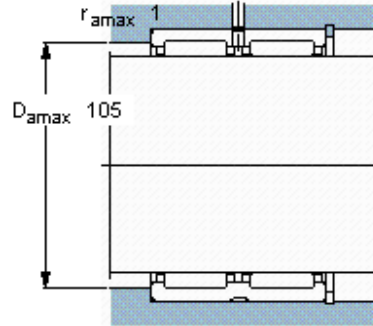
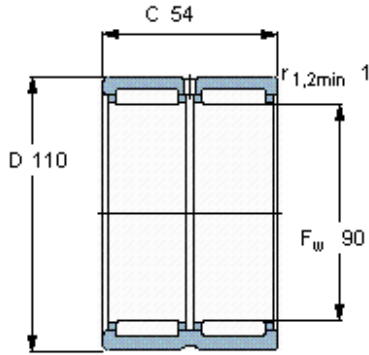

**Appropriate seals**

G seal	-
SD seal	-
CR seal	90x110x10 HMS5 RG